

MULTIGLOW

FIRES

CLASSIC II BM REMOTE CONTROL

INSTALLATION INSTRUCTIONS

The E,F,G and H sizes of the **CLASSIC II** Gas Burner have been approved for installation with a BM733 remote mounted control valve. The following instructions override clauses 5.3 and 5.4 on page 5 of the instruction manual, all other instructions remain the same.

PARTS SUPPLIED:

- (1) VALVE MOUNTING BRACKET.
- (2) BM733 CONTROL VALVE [with 850mm long piezo lead].
- (3) P4-12D CO-PILOT [with 1 Mtr. long Thermocouple lead].
- (4) 1off M4 x 10mm VALVE LOCATING SCREW
- (5) 8mm TEST POINT ELBOW
- (6) 1 mtr. 8mm COPPER PIPE
- (7) 1 mtr. 4mm COPPER PIPE

PRESSURE SETTINGS

GAS TYPE : G20 @ 20mbar. WORKING PRESSURE
NATURAL GAS

SIZE	BURNER TEST PRESSURE [mbar]							
	E		F		G		H	
PIPE LENGTH	HIGH	LOW	HIGH	LOW	HIGH	LOW	HIGH	LOW
0.5 Mtr.	9.1	3.6	11.6	4.0	11.7	3.4	8.7	2.3
0.75 Mtr.	9.0	3.3	11.8	3.9	11.5	3.2	8.5	2.1
1.0 Mtr.	9.1	3.3	11.7	4.0	11.4	3.2	8.4	2.1

INSTALLATION REQUIREMENTS FOR BM REMOTE

BM733 VALVE [850mm PIEZO LEAD]

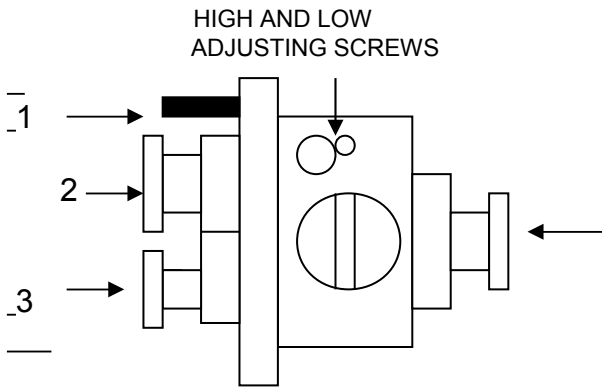

- 1 PIEZO LEAD
- 2 GAS OUTLET
- 3 4mm PILOT OUTLET
- 4 GAS INLET
- 5 THERMOCOUPLE
- 6 4mm PILOT INLET

CO-PILOT P4-12D THERMOCOUPLE [1000mm]

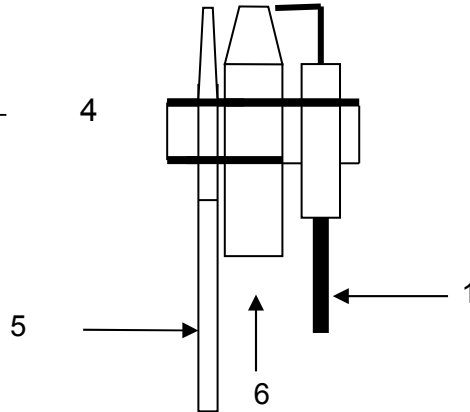

5.3: NOTE: THE PIEZO LEAD FROM THE BM VALVE IS 850mm LONG. THIS MUST BE TAKEN INTO ACCOUNT WHEN POSITIONING THE BM VALVE MOUNTING BRACKET, AN ALLOWANCE MUST ALSO BE MADE FOR CONNECTING THE PIEZO LEAD TO THE CO-PILOT ELECTRODE.

- (a) Fold, locate and fix the valve mounting bracket in position taking into account the note above.
 - (b) Using M4 fixing screw provided mount BM valve to mounting bracket.
 - (c) Connect the piezo lead (1) to pilot electrode.
 - (d) Using the 8mm diameter copper pipe provided connect from gas outlet (2) to Test Point Elbow fitted to burner tray. Care must be taken to ensure that there is no sharp bends, kinks or burs are left in or on the pipe.
 - (e) Using the 4mm diameter copper pipe provided connect from pilot outlet (3) to CO-PILOT inlet (6). Care must be taken to ensure that there is no sharp bends, kinks or burs are left in or on the pipe.
 - (f) Connect the THERMOCOUPLE (5) from pilot to the rear of the BM valve.
 - (g) Using the 8mm copper pipe provided connect from gas inlet (4) via a test point not provided to the gas isolating tap adjacent to the appliance so that when the tap is closed the appliance is totally isolated.
- NOTE: SOFT SOLDERED JOINTS MUST NOT BE USED BENEATH THE BURNER TRAY.**

5.4: (A) Turn on gas supply and check all the joints made between gas isolating tap and the gas inlet on Bm valve for gas soundness. (Tests should be carried out in accordance with current Gas Safety Regulations.)

(B) Light the appliance and set valve to the low position, check all gas joints made from the outlets of the BM valve to the pilot and burner tray test point elbow for gas soundness. (Tests should be carried out in accordance with current Gas Safety Regulations.) Turn off the appliance.

(C) The BM valve has been supplied set in the fully open position. Using two manometers at the pressure test points. Re-light the appliance. Check the BURNER TEST PRESSURE in both the high and low positions (using table above). If necessary adjust both the high and low gas flow rates by turning adjustment screws clockwise so that the correct burner test pressure is achieved. After setting the flow rates, turn off the gas supply, reseal the test pressure points and seal the adjusting screws with a dot of paint. Re-light the appliance and check for gas soundness. (Tests should be carried out in accordance with current Gas Safety Regulations.)