



CLASSIC II QUATTRO

DECORATIVE FUEL EFFECT APPLIANCES FOR USE WITH
NATURAL GAS

**INSTALLATION, SERVICING & USER
INSTRUCTIONS**

THESE INSTRUCTIONS MUST BE LEFT WITH THE USER

MANUFACTURED BY:
MULTIGLOW FIRES
Canterbury Road, St. Nicholas-At-Wade.
Kent. CT7 0PQ

MULTIGLOW 
FIRES



INDEX

SECTION 1. CONFORMITY AND GENERAL NOTES (INSTALLER)

SECTION 2. TECHNICAL DATA (INSTALLER)

SECTION 3. INSTALLATION PARAMETERS (INSTALLER)

SECTION 4. PRE-INSTALLATION CHECK (INSTALLER)

SECTION 5. INSTALLATION (INSTALLER)

SECTION 6. REMOTE CONTROL (INSTALLER & END USER)

SECTION 7. FUNCTION CHECKS & COMMISSIONING
(INSTALLER)

SECTION 8. FINAL CHECKS & CUSTOMER BRIEFING
(INSTALLER)

SECTION 9. SERVICING (SERVICE ENGINEER & END USER)

SECTION 10. END USER INSTRUCTIONS

SECTION 11. BURNER INSTALLATION RECORD AND
WARRANTY INFORMATION

MULTIGLOW 
FIRES



**PLEASE READ THESE INSTRUCTIONS FULLY
BEFORE COMMISSIONING OR USE**

CONFORMITY & GENERAL NOTES

SECTION 1

Because Multiglow Fires believe in the use of modern technology and materials, they reserve the rights to modify or change the layout and controls of their burner trays, at any time, whilst still complying with current specifications.

Therefore these 'Instructions' are a general guide only and not specifically in compliance with the shape or size of your appliance. These units must be installed in line with the current '**GAS SAFETY (INSTALLATION AND USE) REGULATION**' applicable to the country of use.

NOTE: For the safe and efficient operation of this appliance, it must be installed inline with the current British Standard (BS 5871:PART 3) or the equivalent standard for the country of use and take into account the Local and national building regulations or bylaws where necessary.

NOTE: This appliance has been designed for use on NATURAL GAS only. Prior to installation, ensure that the distribution conditions (identification of the type of gas and pressure) and the adjustment of the appliance are compatible.

NOTE: THE WHITE FIBRE BLANKET SHOULD NOT BE REMOVED FROM THE BURNER TRAY.

NOTE: Multiglow Fires will not accept any liability or responsibility for a appliance that has been installed outside of the technical data specified in this manual and is not in agreement with the above statements.

The MULTIGLOW CLASSIC II is a Decorative Fuel Effect (D.F.E.) primary aerated gas fire designed to comply with BS EN 509:2000 and is intended for decorative use only. It has been designed to operate on Natural Gas (N.G.) only and must be fitted on a non-combustible hearth in a standard builders opening, with a class 1 chimney in compliance and satisfying the requirements of BS 5871- PART 3. The appliance has been tested and approved with a flue of 7" (178mm) diameter and having a minimum effective height of 10ft. (3mtrs.)

The MULTIGLOW CLASSIC II conforms to the relevant Safety Standards but during use there are naked flames and parts of the casing become hot. A suitable guard to (BS.6539 fireguards for



use with solid fuel appliances) is therefore recommended where the young, elderly or infirm are concerned.

NOTE: The larger of the units manufactured have gas consumption similar to that of a small boiler (i.e.50000 BTU). Therefore, it is essential that the gas supply pipe work be of a size that will allow for the correct flow rate (See **TECHNICAL DATA** for required information). Ideally the 8mm connection pipe to the burner should be as short as possible and the maximum length should not be greater than 1mtr. Also ensure that the isolating tap does not have a reduced bore.

NOTE: The Box used with this appliance will become hot during use. Care should be taken when operating the controls.

SECTION 2

TECHNICAL DATA

GAS TYPE G20 at 20 mbar CATEGORIES I2H

HEAT INPUT (GROSS kW)	6.95
FLOW RATE (m ³ /h)	0.65
WORKING "P" (mbar)	20
BURNER TEST "P"(mbar)	9.3
REMOTE VALVE	GV60
PILOT OXY DEPLETION DEVICE	OP9039
ONE I NJECTOR	16/650
APPLIANCE MASS (kg)	6.0
DATA LABEL AFFIXED TO BURNER TRAY	

NOTE: This size is rated below 7kw, therefore no vent is required if flue flow for the clearance of the products of combustion is correct.

NOTE: This appliance is to be used with a class 1 flue (7" diameter).

INSTALLATION PARAMETERS

SECTION 3 – REGULATIONS AND CODE OF PRACTICE

3.1 In your own interest and safety it is law that all gas appliances are installed by a competent person, in accordance with the current Gas Safety (Installation and Use)



Regulations applicable to the country of use. In addition, the installation must be carried out in accordance with the relevant and current local and national specifications and building regulations.

- 3.2** The fireplace surround, hearth and builders opening shall be of non-combustible material. Hearth and clearance dimensions must comply with the requirements of BS 5071 part 3. **WARNING:** This appliance must not be fitted in any room where steam is present (e.g. bathroom).
- 3.3** The minimum clearance height above fireplace opening for a combustible shelf (having a depth of 150mm (6") is 200mm (8"), add 12mm (½") for each additional 25mm (1") depth of shelf. **WARNING:** Please note that soft wall coverings may become discoloured when close to a heating appliance – this should be born in mind.
- 3.4** The minimum flue opening is 178mm (7") diameter 250dq. Cm. (38½ sq. inches) and a minimum effective height 3m (10ft). Provided that the flue, which is to serve this appliance, satisfies the requirements of BS 5871:Part 3 then a terminal in-line fan satisfying BS 5440: Part 1 may be used to improve flue draught. **WARNING:** The flue must **NOT** be shared with any other appliance.
- 3.5** All chimney dampers or restrictions should be removed or permanently fixed in the open position. **WARNING:** If the fireplace has previously been used with a solid fuel the flue should be swept clean prior to installation.
- 3.6** The room in which the appliance is to be fitted must have permanent air vent with a minimum effective area of 100cm. Sq. (15½ sq. inches) and be accessible to the outside air, unless specifically stated otherwise by the manufacturer. **NOTE:** Vent should be checked on a regular basis to ensure that there is no obstruction.

PRE-INSTALLATION CHECK

SECTION 4 FLUE SOUNDNESS

- 4.1** Using a smoke bomb, carry out a flue flow test to check the effectiveness of the flue and ensure that there is no leakage into another part of the premises (including any loft) or, as appropriate, other adjoining premises.

NOTE: Although a smoke pellet produces a large amount of smoke, the volume is small compared with the volume of the combustion products from an appliance. Clearance of smoke from a pellet is, therefore, no guarantee that the products of combustion from the appliance will clear. This must be tested after the installation is completed by carrying out a spillage test

WARNING: Smoke coming out of other than the correct terminal, or a down-draught or no-flow condition, indicates as unsatisfactory flue. The flue may need attention – seek expert advice.

VENTILATION

- 4.2** In line with 3.7 above, make sure that the room or space where the appliance is located is adequately ventilated and that the means of ventilation is suitable.



NOTE: The size and type of ventilation should take into account any other gas appliance that may be fitted in the room or space

GAS SOUNDNESS

4.3

“An isolation valve, or valves, has to be fitted adjacent to the appliance, which when closed allows the complete burner and control assembly to be disconnected for maintenance or repair in accordance with national regulations”

COMPATIBILITY

4.4 Before commencing installation, check that the local distribution conditions (identification of type of gas and pressure) and the adjustment of the appliance are compatible.

SECTION 5- INSTALLATION

APPLIANCE LOCATION

The fire must be fitted on a flat non combustible base
Also a non combustible hearth or physical barrier
should be placed in front of the fire opening where
relevant.

This appliance is not fitted with an integral guard. In normal use consideration may be given to the use of a fire guard, which conforms to BS6539, such that accessibility to the naked flame produced by the appliance is minimised.

It may not be desirable with a hole in the wall situation
to include a hearth with the appliance installation.
Building Regulation Approved Document J currently
states:-

A Appliances should be placed on a hearth unless:
They are installed so that every part of any flame
or incandescent material will be at least 225mm
Above the floor

Or

B. The manufacturers instructions state that a
Hearth is not required
Multiglow Fires recommend that a hearth or
physical barrier is installed with this appliance



However should you decide not to follow the recommendation and do not fit a hearth or barrier or decide to remove one or both. Then consideration as to the safety of the occupants of the room should be given.

CONTENTS CHECKLIST

1. Box
2. Four Part Frame (attached to box)
3. Fixing Screws
4. Burner Shelf
5. Burner
6. Refractories
7. 1 x Receiver pack (Inc batteries)
8. 1x Burner Control Unit
9. 1x Nut and Olive for 8mm Inlet Pipe

Preparing the Fireplace Opening

1. Create an opening for the box using the dimensions shown.
2. Shown are the actual box dimensions when creating the hole for the box allow 2-5mm extra for a good fit.

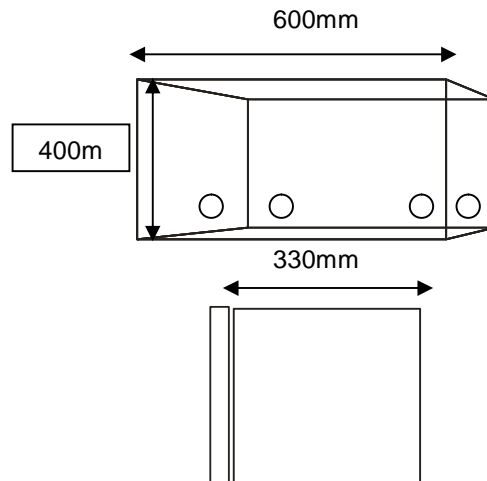

3. The base of the opening must be flat and level.
4. Route the gas supply feed inside the fireplace opening and provision made for it to enter the box through one of the four slots either at the back of the box or at either side.
5. Remove the four pieces of frame by unscrewing the screws, see next page.

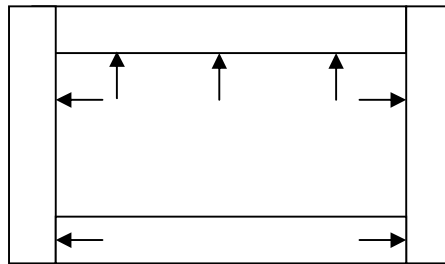

6. Place the box centrally into the opening.
7. Whilst holding the box in place, mark the appropriate holes in the base and roof of the box.
8. Remove the box, drill and plug the respective positions.
9. Replace box and fix with screws supplied.
10. Place burner shelf in the box sliding front legs onto locating pins.

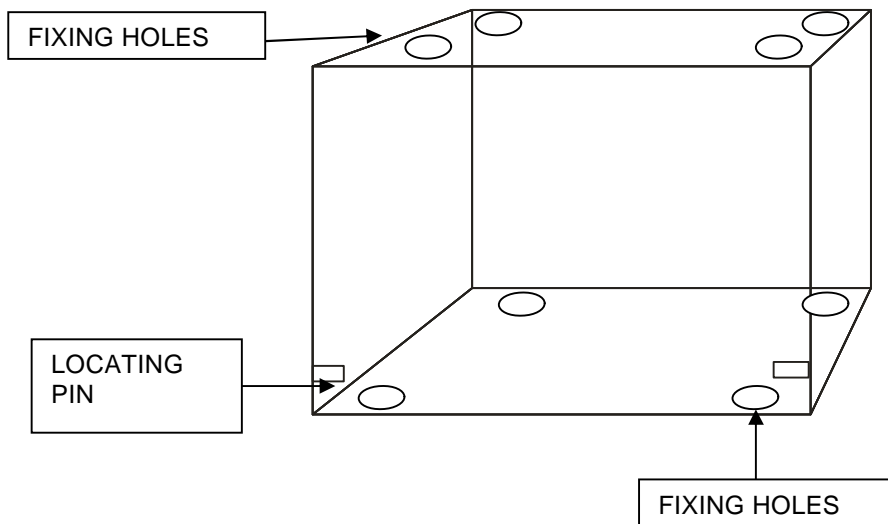

11. Prepare the gas supply pipe for final fixing
12. Fit burner in burner shelf.
13. Fit the four piece frame back onto the box ensuring the bottom flap opens and closes without



too much force.

14. Purge the gas supply pipe work to remove air and debris BEFORE connection of the fire.
The 8mm pipe should be used to connect valve to an isolating tap, which must be adjacent to the appliance (so that when tap is closed appliance is totally isolated). **NOTE**
Soft soldered joints should not be used beneath the burner tray.
WARNING: Flexible pipe must not be used
15. Turn on gas supply and check for gas soundness. (Tests should be carried out in accordance with current Gas Safety Regulations).
16. Place refractories on burner as shown

PEBBLE AND DRIFTWOOD LAYOUT



LAYER 1
1 X LARGE PIECE OF DRIFTWOOD
3 X ROW OF 6 PEBBLES



LAYER 2
1 X MED/LARGE PIECE OF DRIFTWOOD



LAYER 3
4 X MED PIECES OF DRIFTWOOD
1 X SMALL PIECE OF DRIFTWOOD



LAYER 4
4 X MED PIECES OF DRIFTWOOD

TOTAL = 16 PEBBLES, 1 LARGE, 1 MED LARGE, 8 MED OF DRIFTWOOD

**UNDER NO CIRCUMSTANCES MUST YOU CHANGE THE
THE LAYOUT OR QUANTITY OF REFRACTORIES**



SECTION 6. REMOTE CONTROL

MERTIK MAXITROL®

GV60 Remote Electronic Ignition and Control System

OPERATING INSTRUCTIONS

▲ WARNING

If the information in this manual is not followed exactly, a fire or explosion may result causing property damage, personal injury or loss of life.

- A. **BEFORE OPERATING** smell all around the appliance area for gas. Be sure to smell next to the floor because some gas is heavier than air and will settle on the floor.

WHAT TO DO IF YOU SMELL GAS

- Do not try to light any appliance.
 - Do not touch any electrical switch; do not use any phone in your building.
 - Immediately call your gas supplier from a neighbor's phone. Follow the gas supplier's instructions.
 - If you cannot reach your gas supplier, call the fire department.
- B. Use only your hand to push in or turn the gas control knobs. Never use tools. If a knob will not push in or turn by hand, don't try to repair it, call a qualified service technician. Force or attempted repair may result in a fire or explosion.
- C. Do not use this control or any gas appliance if any part has been under water. Immediately call a qualified service technician to inspect the control or gas appliance to replace any part of the control system and any gas control which has been under water.
- D. These instructions are to be referenced as a user guide, and do not supersede appliance manufacturer's lighting instructions.

SPECIFICATIONS

Gas combination control according to CSA or CE approval (see label).

Fuels: CSA: Natural & Propane (LP) gas only;
EN 126: Natural & Propane (LP) gas only.

APPLICATION

e-FLAME is a battery-powered electronic remote ignition and control system for gas appliances with pilot burners and ODS systems.

OPERATING INSTRUCTIONS AUTOMATIC IGNITION

▲ WARNING

When pilot ignition is confirmed, motor turns automatically to maximum flame height.

Follow appliance manufacturer's instructions for gaining accessibility to the gas control and the pilot. When turning main valve knob, do not force. Knob has a slipping clutch, allowing for manual main burner(s) flame height adjustment as well as adjustment to pilot stand by position (see figure 1).

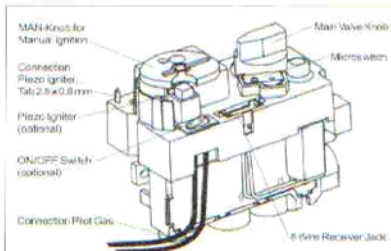







Figure 1: Combination Control GV60



MULTIGLOW Fires





Operating Instructions

1. **STOP!** Read the safety information included before proceeding.
2. For a control equipped with, or for use with, a thermostatic remote, set the thermostat to the lowest setting.
3. Turn main valve knob to the **OFF**, full clockwise  position.
4. Turn MAN-knob to the **MAN**, full clockwise  position.
5. Place manual ON/OFF switch (if equipped) to the **O** (off position).
6. Wait five (5) minutes to clear out any gas. Then smell for gas, including near the floor. **If you smell gas STOP! Follow "A" in the safety information above.** If you don't smell gas, proceed to step 7.
7. Turn MAN-knob to the **ON**, full counterclockwise  position.
8. Place manual ON/OFF switch in **—** (on position).
9. Simultaneously press and hold the  (star) and  (up arrow) buttons (if Infrared Model:  (star up, arrow) and the small lower button) until a short acoustic signal confirms the start sequence has begun; release buttons. Continuing signals confirms the ignition is in process. A short acoustic signal (0.2 sec., 1 Hz) indicates the ignition process is complete and there is main gas flow.

WARNING

When pilot ignition is confirmed, motor turns automatically to maximum flame height.



NOTE: If the pilot does not stay lit after several tries, turn the gas control knob (main valve knob) to **OFF** and proceed to step 11.

10. Set thermostat (if equipped) to desired setting or use remote control to adjust flame. In standby mode; press  (up arrow) to increase flame height, press  (down arrow) to decrease flame height or set appliance at pilot flame.
11. If the appliance will not operate, follow the instructions "TO TURN OFF GAS TO APPLIANCE" and call your service technician or gas supplier.

OPERATING INSTRUCTIONS MANUAL IGNITION

Follow appliance manufacturer's instructions for gaining accessibility to the gas control and the pilot.

When turning main valve knob, do not force. Knob has a slipping clutch, allowing for manual flame height adjustment as well as adjustment to pilot standby position.

1. **STOP!** Read the safety information included before proceeding.
2. Turn main valve knob to the **OFF**, full clockwise  position.
3. Turn MAN-knob to the **MAN**, full clockwise  position.
4. Place manual ON/OFF switch (if equipped) to the **O** (off position).
5. Wait five (5) minutes to clear out any gas. Then smell for gas, including near the floor. **If you smell gas STOP! Follow "A" in the safety information above.** If you don't smell gas, proceed to step 6.
6. Place manual ON/OFF switch in **—** (on position).
7. With the MAN-knob in **MAN** position a manual pilot valve operator is accessible (see figure 2).

- Fully push down manual pilot valve operator and hold in, to start pilot gas flow. Immediately light the pilot with a match, while continuing to hold in the manual pilot valve operator for about one (1) minute after the pilot is lit. Release manual pilot valve operator. If pilot does not stay lit, repeat steps 2 through 6.

NOTE: If the pilot does not stay lit after several tries, turn the gas control knob (main valve knob) to **OFF** and proceed to step 11.

8. If applicable, per appliance manufacturer's instructions, replace pilot access panel before proceeding.
9. Turn MAN-knob to the **ON**, full counterclockwise  position.

MULTIGLOW Fires

e FLAME Operating Instructions

- Turn main valve knob to the full **ON**, full counterclockwise ↺ position
- If the appliance will not operate, follow the instructions "TO TURN OFF GAS APPLIANCE" and call your service technician or gas supplier.

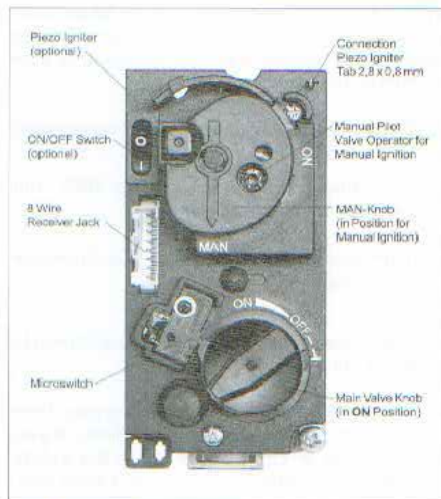

Figure 2: Combination Control, Cover

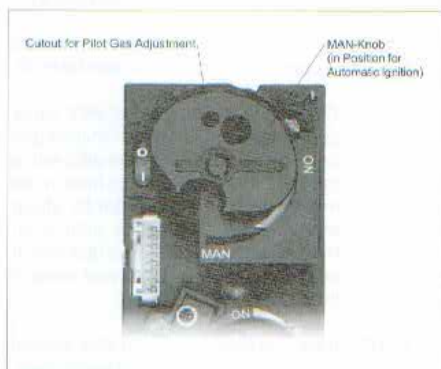

Figure 3: Combination Control, Detail View MAN-Knob

TO TURN OFF GAS TO APPLIANCE

- Follow appliance manufacturer's instructions for gaining accessibility to the gas control.
- Set thermostat (if equipped) to lowest setting.
- Place manual ON/OFF switch in **O** (off position).

- Turn manual valve knob to the **OFF** full clockwise ↻ position.
- Turn MAN-knob to the **MAN**, full clockwise ↻ position.
- Replace appliance accessibility cover (if applicable), per appliance manufacturer's instructions.

NORMAL OPERATION Adjustment - Flame Height

Set thermostat (if equipped) to desired setting or use remote control to adjust flame. In standby mode: press ▲ (up arrow) to increase flame height, press ▼ (down arrow) to decrease flame height or to set appliance at pilot flame (see figure 4).



Figure 4: Remote-Handset, Standard Model

Adjustment - Flame Height, if Infrared Model

To increase flame height press simultaneously ☆ ▲ (star, up arrow) and the small lower button. There is a separate button left for switching off (see figure 5).

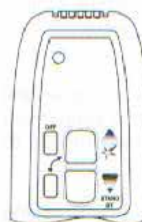

Figure 5: Remote-Handset, Infrared Model

NOTE: (Thermostatic Models) To save battery power, press ▼ (down arrow) to turn main gas to pilot gas. Press OFF button to shut off the device including pilot flame. The device can be shut off with the ON/OFF switch, thus disabling the remote handset.



MERTIK MAXITROL®

HANDSET REMOTE CONTROLS G6R-H

OPERATING INSTRUCTIONS



Figure 1

Figure 2

Figure 3

Figure 4

*Not for use on open front gas fires (CE only).

⚠ WARNING

If the information in this manual is not followed exactly, a fire or explosion may result causing property damage, personal injury or loss of life.

Specifications:

Gas combination control according to CSA or CE approval (see label).

Fuels: CSA: Natural & Propane (LP) gas only;
EN126: Natural & Propane (LP) gas only

Available Remote Handset Models:

- Standard
- Display (figures 3 and 5)
- Timer and Thermostat (figures 4 and 6)

NOTE: For all lighting/ignition instructions please follow the Operating Instructions for the ignition system.

Adjustment - Flame Height

(Standard, Display, Timer/Thermostat Handsets)

In standby mode: Press ▲ (up arrow) to increase flame height. Press ▼ (down arrow) to decrease flame height or to set appliance at pilot flame.

Adjustment - Flame Height

(Infrared Model)

To increase flame height press ✕ ▲ (star, up arrow) and the small lower button simultaneously. There is a separate off switch button.

Setting °C/24 hour or °F/12 hour Clock (Display and Timer/Thermostat Handsets)

1. Press OFF and ▼ (down arrow) until display changes from Fahrenheit/12 hour clock to Celcius/24 hour clock and vice versa.

Setting the Time

(Display and Timer/Thermostat Handsets)

1. The display will flash after either:
 - a. Installing the battery or
 - b. Simultaneously pressing the ▲ (up arrow) and ▼ (down arrow).
2. Press ▲ (up arrow) to set the hour and the ▼ (down arrow) to set the minute.
3. Press OFF to return to manual mode or simply wait and it will automatically return to the manual mode.

Definitions:

(Remaining instructions pertain to Timer/Thermostat Handset ONLY)

★TEMP TEMP MODE – Daytime Temperature Mode: The room temperature is measured and compared to the set temperature. The flame height is then automatically adjusted to achieve the Daytime set temperature.

MULTIGLOW Fires

 Operating Instructions

BATTERY REPLACEMENT

Battery replacement is recommended at the beginning of each heating season. Batteries need to be changed when an acoustic error message appears during ignition (see "POSSIBLE ERROR MESSAGES").

Receiver: 4 x 1.5V "AA"
(quality alkaline recommended)

Remote Handset: 1 x 9V
(quality alkaline recommended)

GENERAL NOTES

A code is preset for all Mertik Maxitrol electronics, but can be changed if required. If you wish to change the code, complete the following:

1. Change DIP switch position (see figure 6).



Figure 6: DIP Switch in Remote Handset Battery Compartment

2. Press and hold the receiver's reset button until you hear 2 acoustic signals. After the second longer acoustic signal release the reset button and within the subsequent 20 seconds, press the ▼ (down arrow) on the remote handset, until you hear an additional long acoustic signal confirming the new code is set (see figure 7).



Figure 7: Receiver with Reset button

POSSIBLE ERROR MESSAGES

Symptom: Long signals (0.8 sec. tone, 0.2 sec. break) during ignition.

Probable Cause: Battery is nearly empty (When signal appears for first time, approximately 10 ignitions left).

Symptom: 5 second continuous tone.

Probable Cause: Error, must be corrected, e.g. cable is not connected, ON/OFF switch is in **O** (off position).

MULTIGLOW Fires

eFLAME Installation Instructions

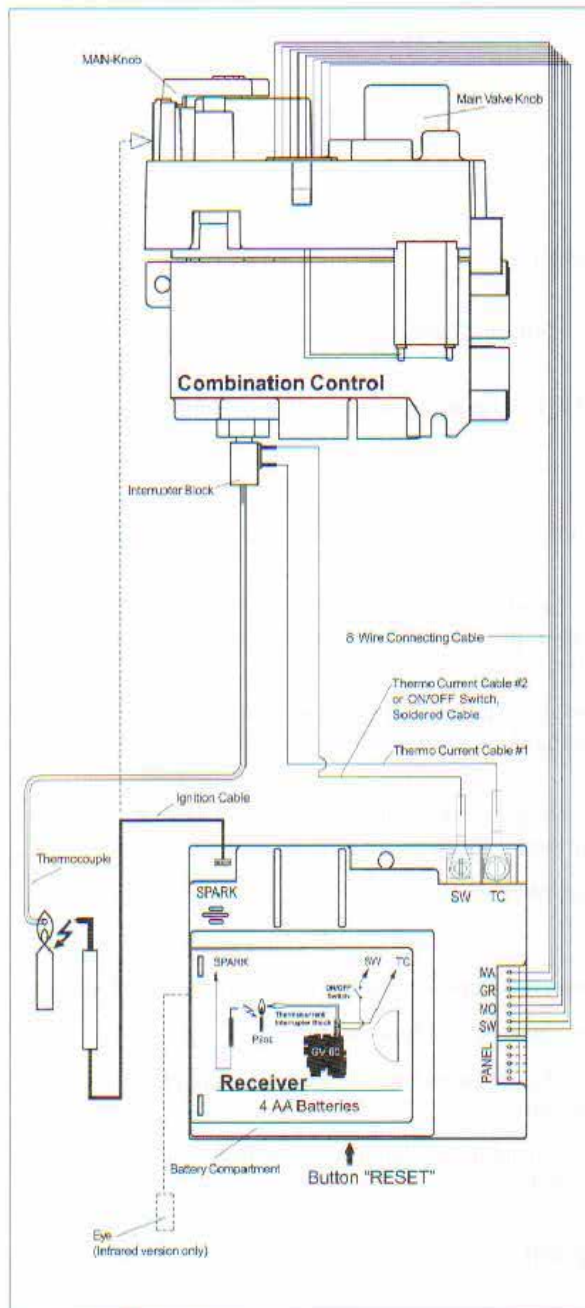

Figure 6: Wiring Diagram

FINAL CHECK

Follow appliance manufacturers lighting instructions or in absence of this use Maxitrol User Instructions GV60-OI-EN-05.2005. Observe several complete cycles to ensure proper operation of the heater. Follow appliance manufacturers lighting instructions. During these cycles the electronics will determine the optimum ignition sequence timing.

WARNING

Fire or explosion hazard. Attempted disassembly or repair can cause property damage, severe injury or death. Do not disassemble the gas valve.



MERTIK MAXITROL®

GV60 Remote Electronic Ignition and Control System

INSTALLER TROUBLESHOOTING GUIDE

▲ WARNING

If the information in this manual is not followed exactly, a fire or explosion may result causing property damage, personal injury or loss of life.

WARNING TO THE APPLIANCE OWNER

▲ WARNING

For your safety, read the user instructions before attempting to light the appliance.

BEFORE OPERATING smell all around the appliance area for gas. Be sure to smell next to the floor because some gas is heavier than air and will settle on the floor.

WHAT TO DO IF YOU SMELL GAS

- Do not try to light any appliance.
- Do not touch any electrical switch; do not use any phone in your building.
- Immediately call your gas supplier from a neighbor's phone. Follow the gas supplier's instructions.
- If you cannot reach your gas supplier, call the fire department.

Do not store or use gasoline or other flammable vapors and liquids in the vicinity of this control or other appliances.

GENERAL NOTES

Wiring of valve and receiver must be completed before starting ignition. An additional wire is required to connect the receiver/metal box to the valve if the receiver is in a metal box or metal heat shield, is separated from the valve, and is not connected by a secure ground (See Observed Problem A).

Installation and service must be performed by a qualified installer, service agency or the gas supplier.

The installation must conform with local codes or in the absence of local codes, with the National Fuel Gas Code, ANSI Z223.1/NFPA 54 or The International Fuel Gas Code or B149.1 in Canada. All piping must comply with local codes and ordinances. Tubing installation must comply with approved standards and practices.

Do not use this control or any gas appliance if any part has been under water. Immediately call a qualified service technician to inspect the control and/or gas appliance and to replace any part of the control system and any gas control which has been under water.

OBSERVED PROBLEM:

- A) Electronics crash during sparking:

POSSIBLE CAUSE:

1. The receiver is in a metal box or metal heat shield, is separated from the valve, and is not connected by a secure ground.

REMEDY:

1. An additional wire is required to connect the receiver/metal box to the valve (see figure 1).

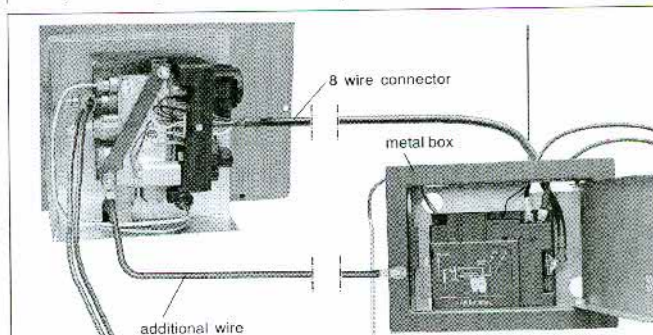

Figure 1

MULTIGLOW Fires

OBSERVED PROBLEM:

B) No Transmission:
(motor does not turn)

POSSIBLE CAUSE:

1. Receiver must learn new code:

2. Dead batteries.

3. The receiver is surrounded by metal, reducing the transmission range.

REMEDY:

1. Press and hold the receiver's reset button until you hear 2 acoustic signals. After the second longer acoustic signal, release the reset button and within the subsequent 20 seconds, press the ▼ (down arrow) on the remote handset until you hear an additional long acoustic signal confirming the new code is set (see figure 2).

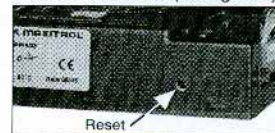

Figure 2: Receiver with Reset button

2. Replace the batteries (Quality Alkaline recommended).

▲ WARNING

Do not use metal tools to remove batteries. Doing so will render the receiver inoperable (see figure 3).



Figure 3

3. Change the position of the adjustable antenna.

▲ WARNING

Make sure that the adjustable antenna is not too close to the electrode cable and ignition coil (beneath the cover). It will damage the receiver (see figure 4).

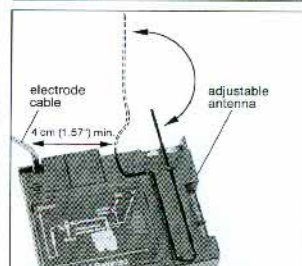

Figure 4

MULTIGLOW Fires



Installer Troubleshooting Guide

OBSERVED PROBLEM	POSSIBLE CAUSE	REMEDY
<p>B) No Transmission: (motor does not turn)</p>	<p>4. Receiver</p> <p>5. Transmitter</p> <p>6. Wiring at valve damaged.</p> <p>7. Bent pins on 8 wire connector (see figure 1).</p>	<p>4. Replace receiver and reprogram code (see Observed Problem B, Remedy 1).</p> <p>5. Replace the transmitter and reprogram code (see Observed Problem B, Remedy 1).</p> <p>6. Replace valve.</p> <p>7. Straighten pins on 8 wire connector.</p>
<p>C) No Ignition:</p>	<p>1. ON/OFF switch in OFF position. Manual override knob in MAN position.</p>	<p>1. Turn ON/OFF switch to ON position and the manual override knob to the ON position (see figure 5).</p>
		
<p>D) No Ignition; No Tone:</p>	<p>1. Receiver</p>	<p>1. Replace receiver and reprogram code (see Observed Problem B, Remedy 1).</p>
<p>E) No Ignition; One 5 second continuous tone (7 short beeps might be heard prior to the 5 second tone):</p>	<p>1. ON/OFF switch is in OFF position.</p> <p>2. Loose wire.</p> <p>3. Receiver</p> <p>4. Bent pins on 8 wire connector (see figure 1).</p> <p>5. Valve</p>	<p>1. Push switch to ON position (see figure 5)</p> <p>2. Secure wire.</p> <p>3. Replace receiver and reprogram code (see Observed Problem B, Remedy 1).</p> <p>4. Straighten pins on 8 wire connector.</p> <p>5. Replace valve. Do not overtighten the thermocouple interrupter.</p>
<p>F) No Pilot Flame and control continues to spark:</p>	<p>1. Air in the pilot supply line.</p> <p>2. Thermocouple circuit wired incorrectly.</p> <p>3. No spark at pilot burner.</p> <p>4. Valve</p> <p>5. Over tightened thermocouple interrupter.</p> <p>6. Receiver</p>	<p>1. Purge the line or start ignition several times.</p> <p>2. Check polarity of the thermocouple wires.</p> <p>3. Check manufacturer's instructions for pilot setup; check wiring connection. Check for spark in location along cable.</p> <p>4. Replace valve. Do not overtighten the thermocouple interrupter.</p> <p>5. Replace valve and thermocouple interrupter.</p> <p>6. Replace receiver and reprogram code (see Observed Problem B, Remedy 1).</p>
<p>G) Pilot is lit and control continues to spark. Valve shuts off after 10...30 seconds. Valve operates manually:</p>	<p>1. Receiver</p>	<p>1. Replace receiver and reprogram code (see Observed Problem B, Remedy 1).</p>

Figure 5

MULTIGLOW Fires

OBSERVED PROBLEM

- H) Pilot is lit and sparking stops. Valve shuts off after 10...60 seconds. Valve does not operate manually:

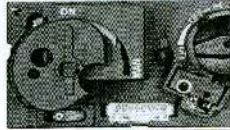
Note: For manual operation turn the valve knob to the manual position and hold the safety magnet open with a pen for approximately 60 seconds (see figure 6).

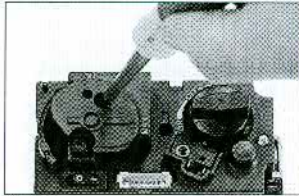

Figure 6

- I) 3 short beeps while the motor turns:

- J) Pilot flame lights but there is no main gas flow:

POSSIBLE CAUSE

1. Not enough voltage generated from the thermocouple or too much resistance in the circuit.

Note: To find which part of the circuit is causing the problem, a checklist for each application can be prepared using an Excel calculation available from Mertik Maxitrol.

Possible parts causing excessive resistance are: ON-OFF switch, Temperature switches, Thermo current connections, Receiver.

2. Thermocouple
3. Low inlet pressure to valve.
4. Valve

1. Batteries are low.

1. Manual override knob (if equipped) is in MAN position.
2. Valve turned down to pilot flow.
3. Low inlet pressure to valve.
4. Valve.

REMEDY

1. Use a digital multimeter set in the mV range and measure the voltage by connecting the test leads to the spade connector. Spade connector is located on the outer surface, directly beside the magnet nut (see figure 7). The available voltage must be at least 5mV. The manufacturer must specify the drop time for the application. The drop time can be measured after the thermocouple is heated.

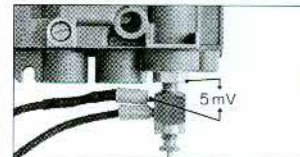

Figure 7

2. Replace thermocouple.
3. Confirm sufficient inlet pressure to the valve. Adjust or replace inlet regulator if necessary.
4. Replace valve. Do not overtighten the thermocouple interrupter.

1. Replace batteries (Quality Alkaline recommended).

▲ WARNING

Do not use metal tools to remove batteries. Doing so will render the receiver inoperable (see figure 3).

1. Turn Manual override knob to ON position (see figure 5).
2. Turn flame to high fire by pressing up button on remote handset.
3. Confirm sufficient inlet pressure to the valve. Adjust or replace inlet regulator if necessary.
4. Replace valve. Do not overtighten the thermocouple interrupter.



SECTION 7. FUNCTION CHECKS & COMMISSIONING

Check that the valve and remote control are all functioning properly. If there is a problem double check the trouble shooting guide in section 6.

REFERENCE PRESSURE

7.0 The appliance is pre-set to the given heat input for the inlet pressure given on the Data Plate. No further adjustment should be necessary. However, the burner can be checked by fitting a pressure gauge at the Test Point accessible to the left of the Control Valve. The pressure should be checked with the appliance alight and the control set at 'High'. After checking pressure, turn off appliance, remove Pressure Gauge, replace Test Point Seal and check gas soundness.

CHECK FOR SPILLAGE

IMPORTANT: A SPILLAGE CHECK MUST BE MADE BEFORE THE INSTALLED APPLIANCE IS HANDED OVER TO THE CUSTOMER.

This test is to be carried out with the appliance fully fitted and front flap in position.
Close all doors and windows of the room in which the appliance is fitted.
Light the fire and set the control to maximum and leave for five (5) minutes.
After five (5) minutes, light a smoke match and position flush with fireplace opening, a minimum of 50mm (2") from side and a maximum of 50mm (2") from top.

The installation is satisfactory if the smoke is drawn into the chimney and out of the room. If this does not happen then leave alight for a further ten (10) minutes and check again.

WARNING: If smoke is still not drawn up the chimney, turn off and disconnect the appliance and seek expert advice.

WARNING: If the fire goes out under normal operation and continues to go out after relighting, spillage has occurred and the flue should be checked.

This appliance is fitted with a pre-set Oxygen Depletion System incorporated into the Pilot Ignition Unit. Therefore this system must not be adjusted or put out of operation and must be replaced with a complete unit of original manufacture in the event of renewal.

SECTION 8. FINAL CHECK & CUSTOMER BRIEFING

- 8.0** Instruct the customer on the full operation of the appliance.
- 8.1** Recommend to the customer that a competent person should service the appliance annually.
- 8.2** Recommend to the customer that on a yearly basis the flue should be swept and that rubbish should not be thrown or burnt on the fire or fuel bed disturbed.



8.3 Instruct the customer that the pilot and flame-sensing device fitted to this fire also acts as an atmospheric sensing device, which shuts off the appliance if the evacuation of the products of the combustion is interrupted.

If the fire shuts off, restart the main burner as stated in section 6. If the appliance fails to relight or repeatedly cuts off, then do not use and inform a qualified person.

8.4 Inform customer of end users instructions Sections 10& 11 of this manual.

8.5 Hand over these User instructions to the customer.

SECTION 9. SERVICING

SPARES LIST

FIG. No.	DESCRIPTION	PART No.	QTY.
1	PILOT BURNER & IGNITION UNIT	9039	1
SEC 6	CONTROL VALVE	GV 60	1
SEC 6	RECEIVER PACK	G6R PISOA5AS10	1
SEC 6	4 X AA ALKALINE BATTERIES 1 X 9 VOLT BATTERY	ENERGIZER	4, 1

Fig 1.

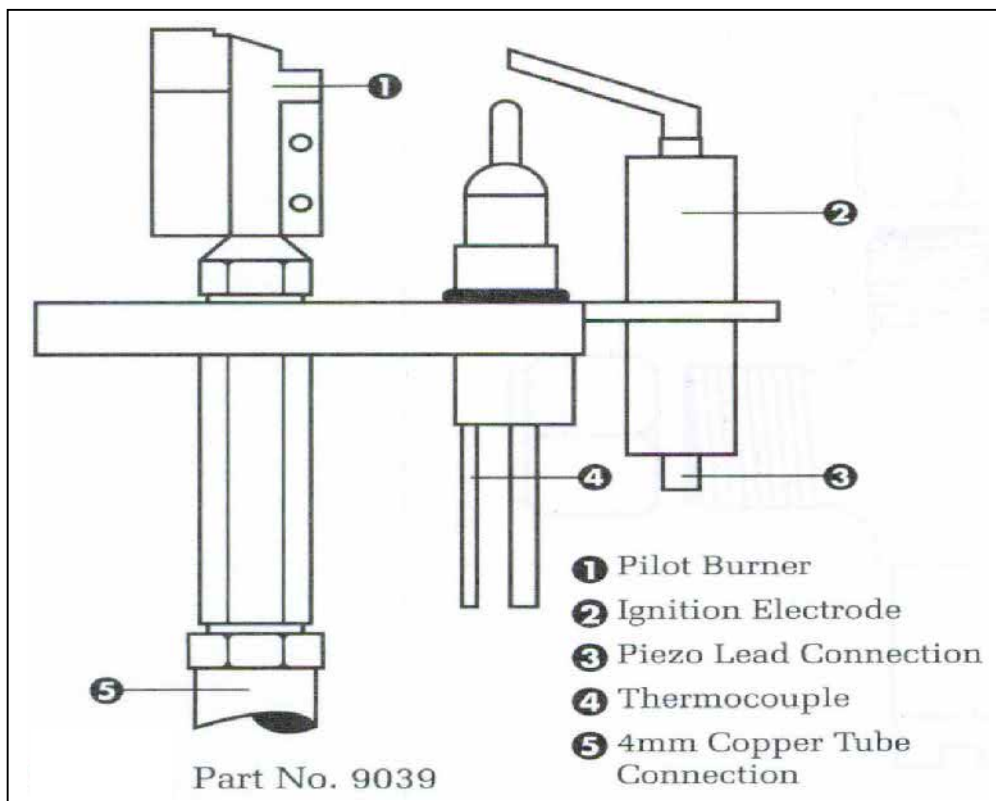

All servicing of this appliance is to be carried out by a competent person.



Turn off gas supply before commencing any servicing. Always check for gas soundness and spillage after refitting the appliance.

9.1 GENERAL MAINTENANCE

At yearly intervals, turn off and allow to cool down. Check all refractories, pilot burner/ignition unit, for soot or debris deposits. These can cause imperfect flame appearance and should be removed by brushing with a soft brush (DO NOT USE A VACUUM CLEANER). Replace all misplaced pebbles/driftwood as per layout (see page 9) and relight.

NOTE: On the failure of either the pilot burner/ignition unit, or main control valve, have repairs carried out by a competent person.

9.2 RENEWING PILOT BURNER/IGNITION UNIT (Fig.1)

- 9.2.1 Isolate gas supply.
- 9.2.2 Remove all refractories– store in a safe place.
- 9.2.3 Disconnect main 8mm gas supply pipe from control valve (See section 6)
- 9.2.4 Remove appliance from tray.
- 9.2.5 Undo and remove thermocouple nut from the rear of the control valve.
- 9.2.6 Disconnect and remove piezo ignition wiring from ignition electrode (Fig.1 (2))
- 9.2.7 Undo and remove the 4mm gas supply pipe from the bottom of the pilot burner (Fig.1 (5))
- 9.2.8 Undo and remove 2x 4mm locating nuts/screws on pilot/ignition unit. Remove unit.
- 9.2.9 Replace with a new unit and reassemble in reverse order.

SECTION 10. END USER INSTRUCTIONS

10.0 For safe operation of this appliance which includes lighting and shut-down procedures, including instructions in the event of remote breakdown (manual ignition) please refer to section 6 of this manual.

- 10.1** The chimney shall be swept regularly to ensure that all products of combustion are entering the flue, and that there is no excessive build up of soot.
- 10.2** Any debris from any source or any soot shall require removal; this must be done by using a soft brush (DO NOT USE A VACUUM CLEANER).
- 10.3 THE USER IS WARNED NOT TO THROW RUBBISH ON OR OTHERWISE DISTURB THE FUEL BED.**
- 10.4 WHERE IT IS NECESSARY TO REMOVE THE REFRACTORIES FOR CLEANING PURPOSES, THIS MUST BE DONE USING A SOFT BRUSH (DO NOT USE A VACUUM CLEANER). WHEN REPLACING THE REFRACTORIES THIS MUST BE DONE AS PER LAYOUT SHOWN ON NEXT PAGE, UNDER NO CIRCUMSTANCES SHOULD THE LAYOUT BE CHANGED OR MORE REFRACTORIES ADDED OR TAKEN OFF.**

MULTIGLOW *Fires*

FIG 1



FIG 2



FIG 3



FIG 4



FIG 1, LAYER 1
1 X LARGE PIECE OF DRIFTWOOD
3 X ROW OF 6 PEBBLES

FIG 3, LAYER 3
4 X MED PIECES OF DRIFTWOOD
1 X SMALL PIECE OF DRIFTWOOD

FIG 2, LAYER 2
1 X MED/LARGE PIECE OF DRIFTWOOD

FIG 4, LAYER 4
4 X MED PIECES OF DRIFTWOOD



PLEASE FILL IN INFORMATION BELOW FOR FUTURE REFERENCE INFORMATION C

MODEL	
SERIAL NUMBER	
INSTALLER	
INSTALLATION DATE	

		MODEL	DATE
	SERIAL NO		

WARRANTY INFORMATION

If within the period of one year of purchase there is the unlikely occurrence of defect in either materials or workmanship Multiglow will arrange to repair or replace the item free of charge.

All warranty claims must be made through the retailer that this appliance was purchased through.

Multiglow are not able to discuss with the purchaser any claim until the retailer has inspected a claim and deemed it valid this being due to the fact that the purchaser's contract of sale is with the retailer.

When a defect is due to installation error or misuse Multiglow reserve the right to refuse service or make the appropriate charge for any warranty call.

